

RESET SWITCH

IF BLASTER SEEMS JAMMED OR PRIMING SLIDE SEEMS STUCK, PULL RESET SWITCH DOWN AND PULL THE SLIDE BACK. REMOVE ANY JAMMED ROUNDS FROM BREECH. MAKE SURE YOU AIM THE BLASTER AWAY FROM YOURSELF AND ANYONE ELSE WHILE RELEASING JAMMED ROUNDS.

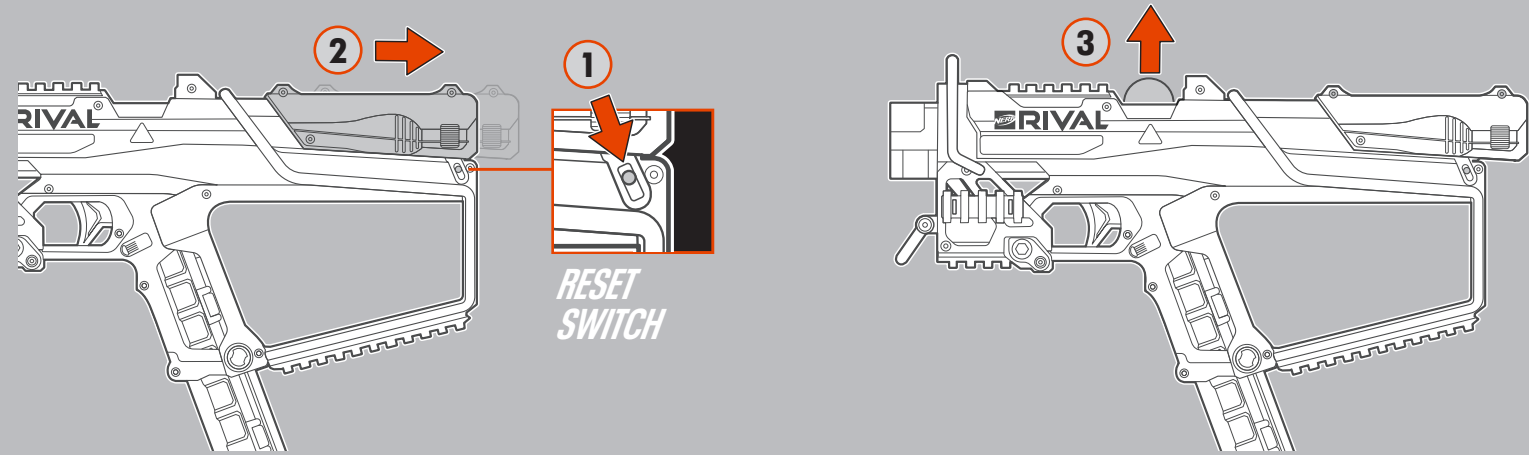

STORING YOUR BLASTER

DO NOT STORE BLASTER PRIMED AND READY TO FIRE.

MAGAZINE IS COMPATIBLE WITH MOST NERF RIVAL MAGAZINE-FED BLASTERS.

Keep away from pets.
NERF and HASBRO and all related trademarks and logos are trademarks of Hasbro, Inc. © 2024 Hasbro TM & © denote U.S. Trademarks.
Hasbro, Pawtucket, RI 02861-1059 USA. HASBRO CANADA, LONGUEUIL, QC, CANADA J4G 1G2. US/CANADA TEL. 1-800-255-5516.

F8444

PN00085025

NERF.COM



TO AVOID EYE INJURY:

WARNING: Do not aim at eyes or face. Use of eyewear recommended for players and people within range. Use only official Rival rounds. Other rounds may not be safe. Do not modify rounds or blaster.

14+

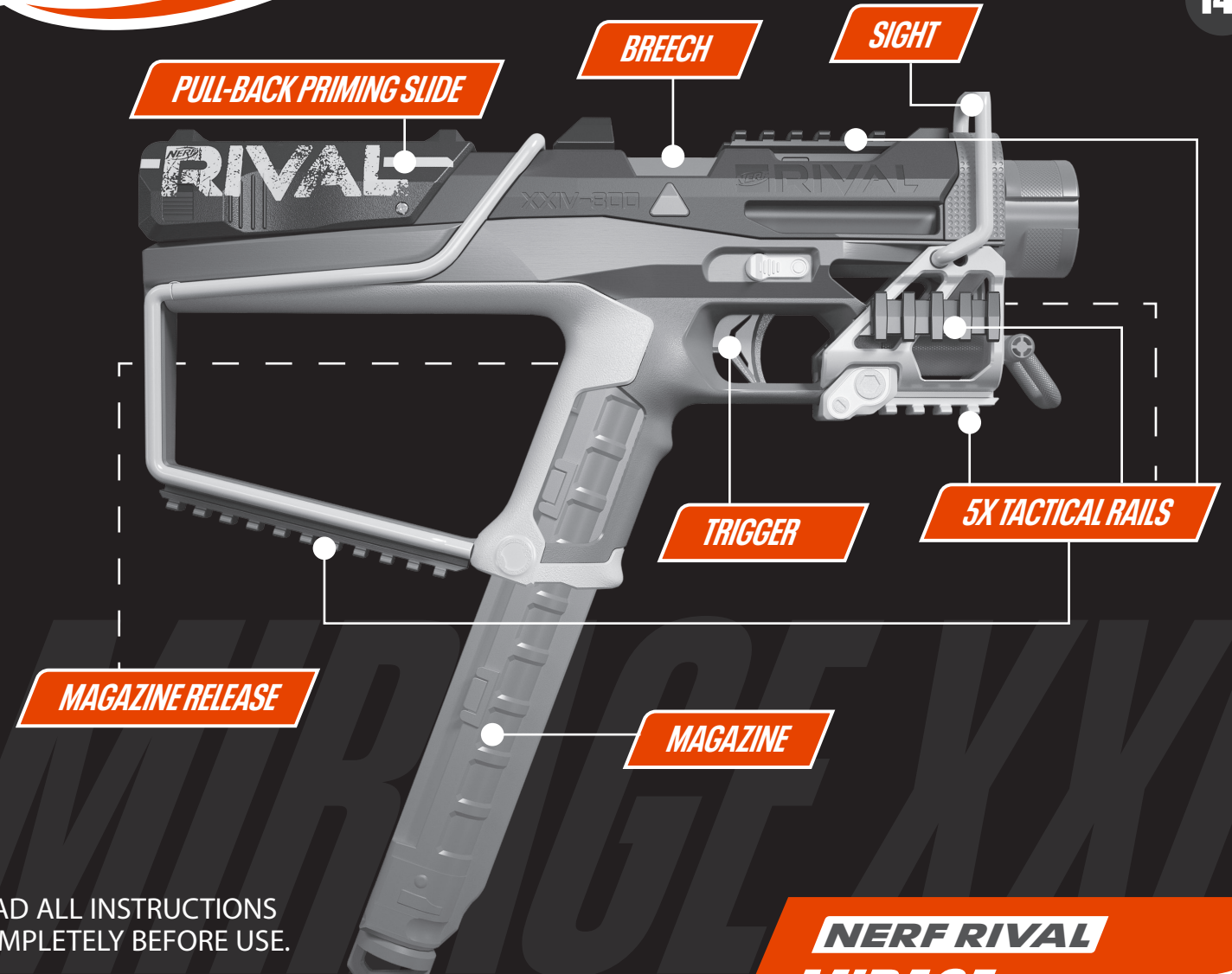

READ ALL INSTRUCTIONS COMPLETELY BEFORE USE.

NERF RIVAL

MIRAGE XXIV-800™



TRIGGER LOCK

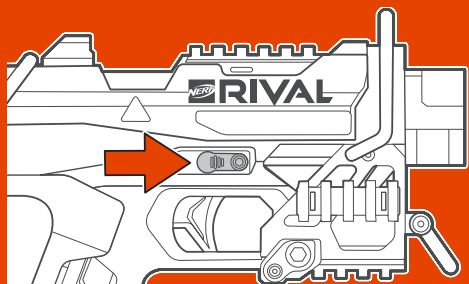

SLIDE TRIGGER LOCK FORWARD TO LOCK AND SLIDE IT BACKWARD TO UNLOCK. ALWAYS PUT THE TRIGGER LOCK IN LOCKED POSITION WHEN BLASTER IS NOT IN USE AND WHEN STORING BLASTER.

LOAD

2 WAYS TO LOAD MAGAZINE

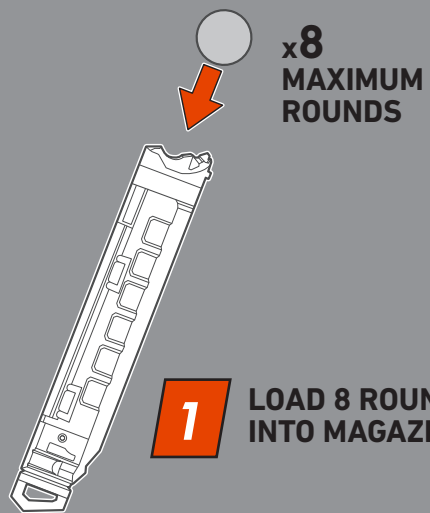

1 LOAD 8 ROUNDS INTO MAGAZINE.

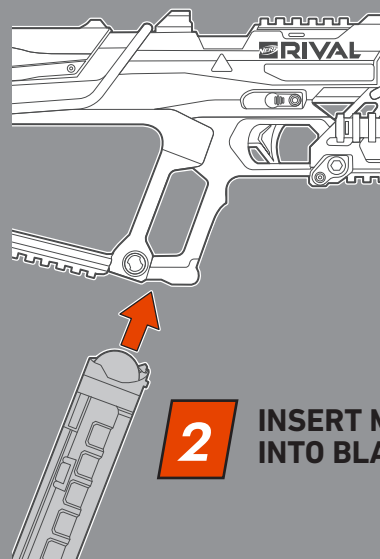

2 INSERT MAGAZINE INTO BLASTER.

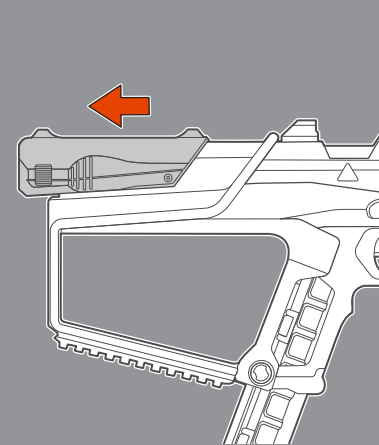

1 WHEN MAGAZINE IS INSERTED IN BLASTER, PULL SLIDE BACK.

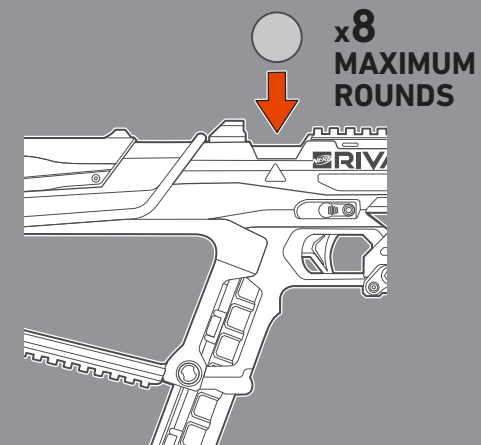

2 LOAD ROUNDS INTO THE BREECH TO RELOAD THE MAGAZINE.

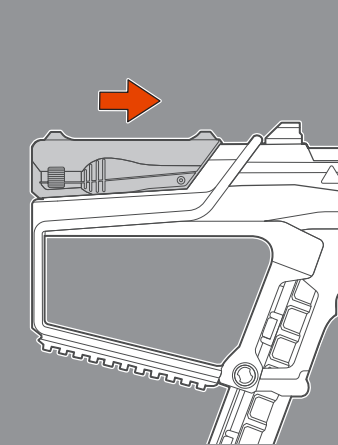

3 PUSH SLIDE FORWARD.

FIRE

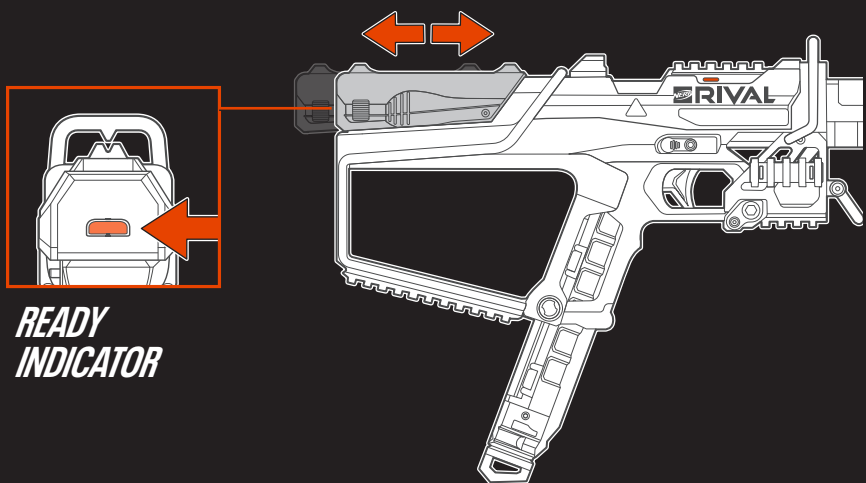

READY INDICATOR

1 PULL PRIMING SLIDE ALL THE WAY BACK AND PUSH IT ALL THE WAY FORWARD. BLASTER IS FULLY PRIMED WHEN READY INDICATOR IS VISIBLE.

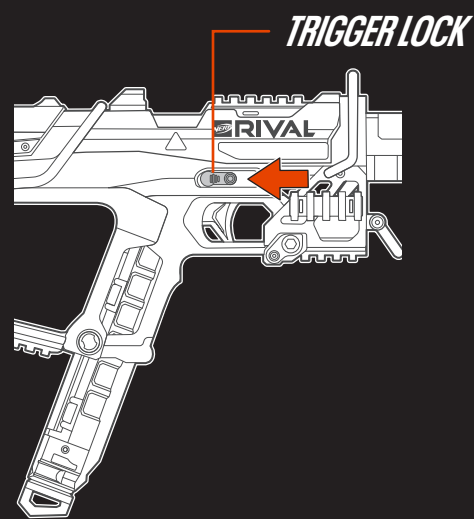

2 UNLOCK TRIGGER.

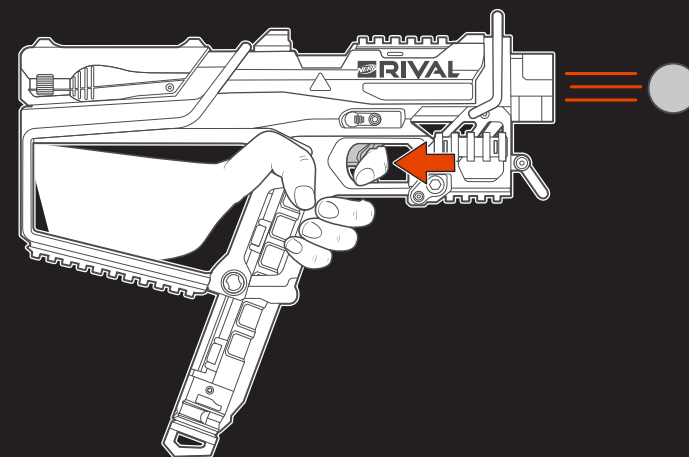

3 PULL TRIGGER TO FIRE 1 ROUND.

MAGAZINE REMOVAL

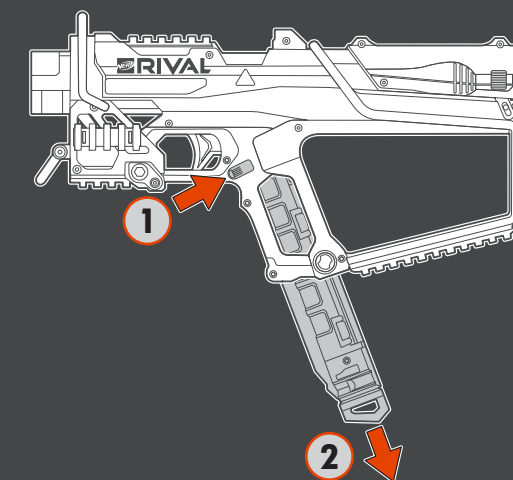

PRESS MAGAZINE RELEASE TO REMOVE MAGAZINE.